



Permskaya Gres power plant in Dobryanka, Russia



Customer Success Story

Permskaya Gres Dobryanka, Russia

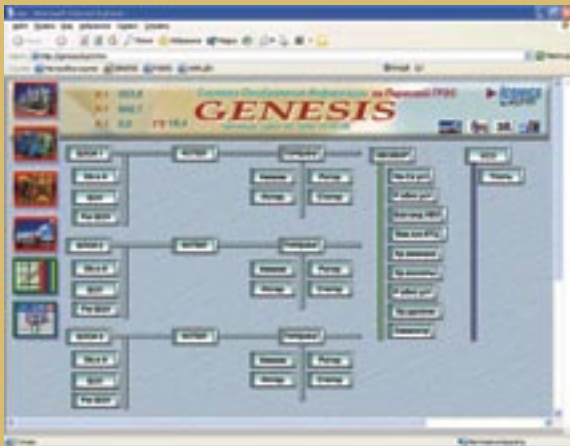

Overview Screen at Permskaya Gres

About Permskaya Gres

The revised Permskaya Gres thermal electric power plant was built and put into operation in 1986, 1987 and 1990 with three 800-megawatt power units. The station burns gas for fuel. Since it went into operation Permskaya Gres has produced 112,000 million kilowatts of electricity. At times its annual output reaches 14,000 million kilowatt-hours. The station produces and delivers electricity to the federal (all-Russian) wholesale electric power market; the thermal energy it produces is delivered to consumers in the town of Dobryanka.

ICONICS Software Deployed

GENESIS32™ Enterprise, WebHMI and DataWorX32 are used throughout the plant. The GENESIS32 En-

terprise system is monitoring and controlling over 11,000 OPC tags. DataWorX32™ is aggregating the data from 3 different OPC servers and delivering the data in real time to the ICONICS TrendWorX32™ and AlarmWorX32™ modules of GENESIS32.

WebHMI™ from ICONICS also plays a critical role in the application. There are several remote monitoring stations in building 500-700 meters apart and WebHMI is used to allow the remote secure access. The list of WebHMI users range from Senior Machine operators in the power generating units to shift supervisors, department chiefs and engineers performing research in the laboratories.

Project Summary

The goals of the project are to increase the control efficiency and capacity for all power stations. Permskaya Gres calls this project “Planned Capacity Trend functionality”. The main purpose of the application is to provide information from different power generating control systems and delivering the information in real-time to remote users.

Project Summary

The first sub-system is monitoring signal system, circuits, and trends of chemically clean water treatment from all power generating units that are producing thermal electric power. The second sub-system is monitoring the planned capacity and working capacity of all power generating units. In total there are 15 nodes running a blend of Windows Server 2000 and Windows XP and storing information data to INFORMIX and Microsoft SQL Server.

The OPC server used is called UNIOPC from Fastwell. There are several different information systems were data is coming from for this project. The systems work independently, have different hardware and software platforms and are placed far from each other. The challenge was to synchronize all this real-time OPC information. DataWorX32's from ICONICS with built in OPC Data Bridging, Aggregation and Redundancy delivered the robust functionality desired.

The system was developed in house in just under one year with a staff of 2 programmers 1 technician and 1 industrial engineer. Permskaya Gres also evaluated HMISCADA solutions from competitors and felt GENESIS32 from

Conclusion

Permskaya Gres has achieved there goal to increase the control efficiency and capacity for all power stations with the "Planned Capacity Trend System". Future plans include additional analysis functionality and growing the number of secure remote users.

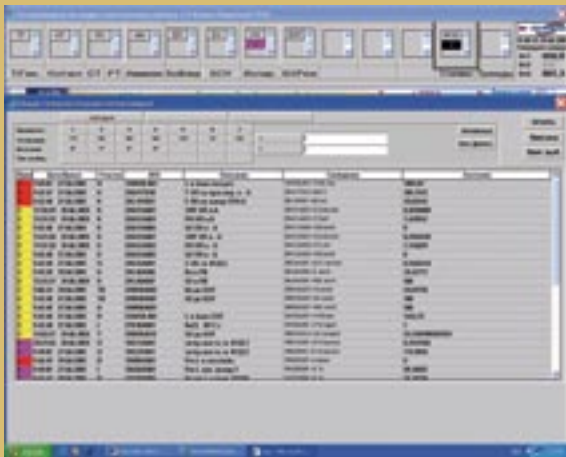

An Alarm Summary Screen at Permskaya Gres Power Plant

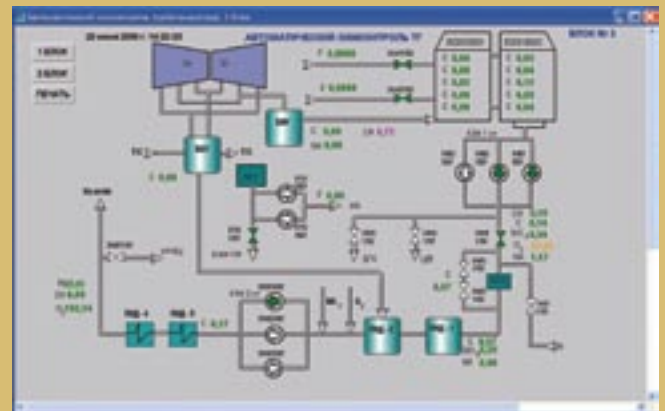

A Power Plant Control Screen

ICONICS offered more features, more flexibility, has a tighter integration with Microsoft applications, and was less expensive. Permskaya Gres estimates over a 2x cost savings for just the development by selecting ICONICS.

Benefits of the System

The system in place at the Permskaya Gres power plant has provides numerous benefits such as:

- Complete aggregation from multiple control systems
- Whole new level of visualization to real-time information
- Secure, real-time data to remote users
- Prevention of equipment failure with data analysis
- Forecast planning for capacity usage

Product Highlight

WebHMI™

WebHMI's Web publishing wizard publishes graphics, trends, reports and alarms to designated Web servers running Microsoft Personal Web Server or Microsoft Internet Information Server (IIS). Users can turn any application into a Web-enabled Digital Dashboard, integrating real-time factory and business information. WebHMI's flexibility allows pages to be spread out over multiple networked Web servers.